

pulse

The ElringKlinger AG Magazine | Issue 2018

Foresight

ElringKlinger took a lead in charting a course for today's and tomorrow's world of mobility

All-rounder

A milestone on the road to e-mobility: hydrogen-powered fuel cells

On the up

CEO Dr. Stefan Wolf joins Martin Schmitt to discuss the similarities between ski jumping and automotive transition



elringklinger

ElringKlinger – Facts & Figures

EXPERIENCE MOBILITY – DRIVE THE FUTURE

Embracing this motto, ElringKlinger is committed to working on pioneering product solutions and innovative technologies.

GROUP REVENUE 2017

1,664.0

MILLION EUROS

9,611

employees were working for the ElringKlinger Group all over the world at the end of 2017.

1
NO.

ElringKlinger is the world's leading supplier of cylinder-head gaskets. The company also holds a premier position in the other established areas of its business.

48°30'43"N, 9°21'45"E

ElringKlinger's corporate headquarters are located in Dettingen/Erms, Germany, approx. 40 kilometers south of Stuttgart.

GLOBAL PRESENCE

49 sites

ElringKlinger is represented worldwide, covering all the major automotive markets and located in close proximity to its customers.

FOUNDING YEAR

1879

ElringKlinger can look back on a rich history. The origins of today's company date back to the end of the 19th century, when Paul Lechler established a trading enterprise for technical products and gaskets in Stuttgart.

SOCIAL MEDIA

@elringklinger

ElringKlinger can be found on the social media networks of Facebook, Twitter, Xing, and YouTube (Elring – Das Original).

As an automotive supplier, ElringKlinger has become a trusted partner to its customers – with a firm commitment to shaping the future of mobility. Be it optimized combustion engines, high-performance hybrids, or environmentally-friendly battery and fuel cell technology, ElringKlinger provides innovative solutions for all types of drive systems. ElringKlinger's lightweighting concepts help to reduce the overall weight of vehicles. As a result, vehicles powered by combustion engines consume less fuel and emit less CO₂, while those equipped with alternative propulsion systems benefit from an extended range. In response to increasingly complex combustion engine technology, the Group also continues to make refinements with regard to gaskets in order to meet the highest possible standards. This is complemented by solutions centered around thermal and acoustic shielding technology. Additionally, the Group's portfolio includes products made of the high-performance plastic PTFE which are also marketed to industries beyond the automotive sector.

Dear Reader,

the world of mobility has undergone rapid change, wouldn't you agree? A decade ago, the smartphone transformed the mobile communications sector. Similarly, the electric drive will have a significant impact on the automotive industry during the next five years. The heart rate of this process is steadily increasing – with the prospect of many new alternative-powertrain vehicles flooding onto the market from 2020 onward. We at ElringKlinger are well prepared and have our finger firmly on the pulse of developments. To take a closer look at what we are working on and how we see the future, please feel free to browse through our new magazine – “pulse.”

I hope you find it both interesting and inspiring.

Dr. Stefan Wolf,
CEO of ElringKlinger AG





22 Production-ready

Partnership with prospects:
ElringKlinger and hofer
powertrain join forces.



32 Pacesetters

Around the globe
ElringKlinger employees
are actively shaping
the future of mobility.



26 Enlightened

Structural lightweighting
is one of ElringKlinger's
future-looking fields of
business.



38 All-rounder

Welcome aboard: a hydro-
gen-powered fuel cell can
significantly extend the
range of electric vehicles.

C

ontents

- 10 On the up
- 14 Foresight
- 22 Production-ready
- 26 Enlightened
- 32 Pacesetters
- 38 All-rounder
- 44 Global presence
- 45 Imprint

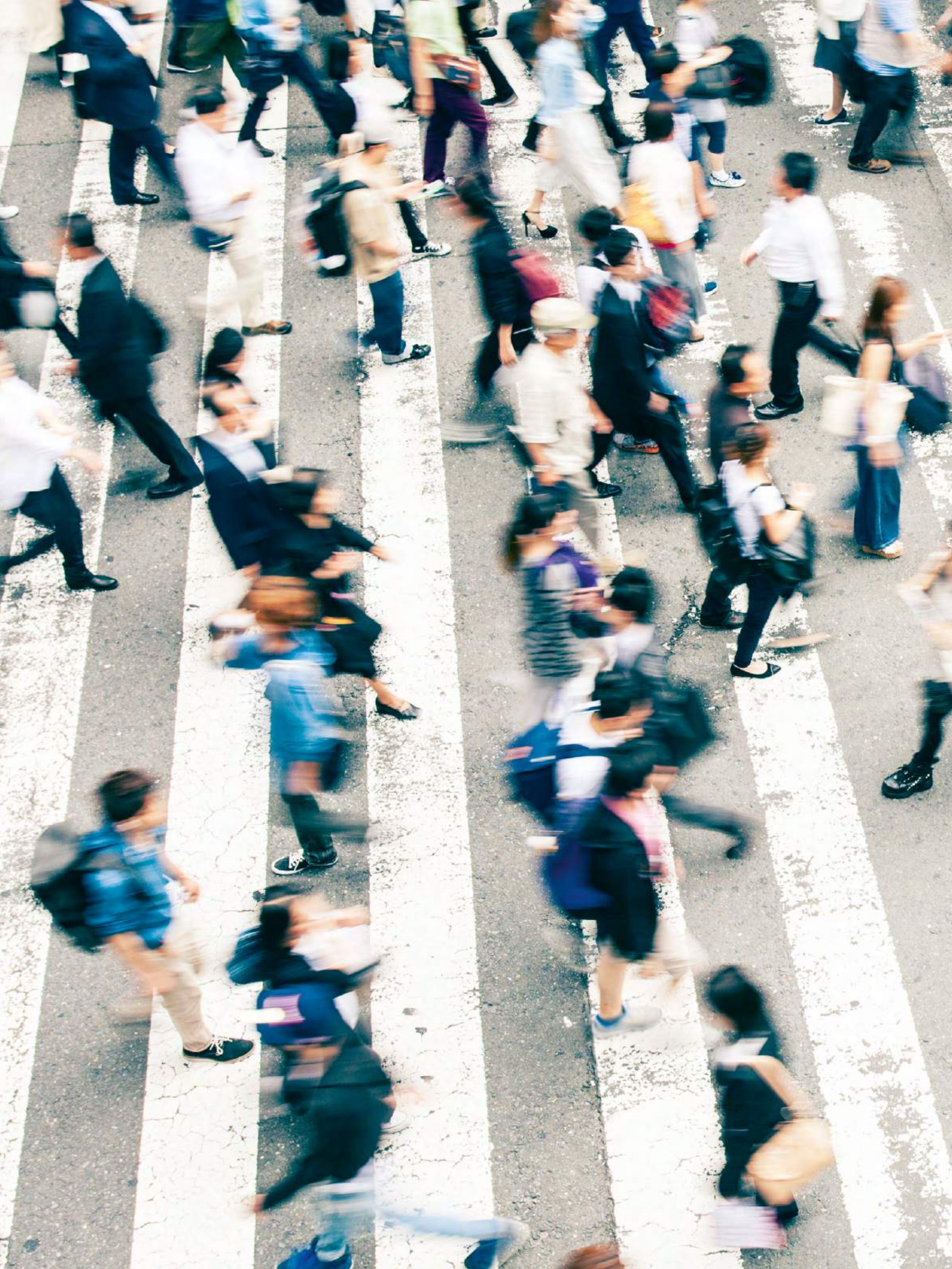



Our lives are in
a state of flux. We
long for stability,
while also striving
for progress.

The result is a process
of continuous change and
ongoing transition.





Our ambition is
to help shape this
transition in a
responsible manner.

ON THE UP



Whether you are a competitor in the Olympic ski jump or an automotive industry supplier trying to stay ahead in the face of rapid change, it takes a lot of preparation to achieve the perfect take-off, maintain your balance, outdistance your opponents, and then make a safe landing. ElringKlinger CEO Dr. Stefan Wolf met ski jump legend Martin Schmitt at Hinterzarten skiing museum in the Black Forest to discuss the matter.



WOLF — As a professional, does fear still play a part when you're standing at the top of the ramp waiting for a really important jump?

SCHMITT — Over time it becomes a routine, but even after all those years you still ask yourself if you really want to do this. If you look at it objectively, you are not putting your body under that much physical strain at that moment, but even so your heart rate can go up to 150 bpm.

WOLF — Do you manage to keep that fear under control?

SCHMITT — Yes. Ultimately, you have to feel that you are on top of the situation. When you are preparing yourself mentally for a jump, you have to ask yourself whether your fear is justified. That's when it can help to look back at key situations

in the past. Every victory is a confidence booster. Of course, those kinds of situation don't just apply to ski jumping. You find them at work, too. Again, the first thing is to check carefully that you have put everything in place that needs to be there for you to succeed. I'm sure that must be the case at ElringKlinger, too.

WOLF — Absolutely! With the advent of electromobility, the automotive industry faces some huge changes, and many are afraid of that. The key factor here, too, is preparation. We commenced with the development of fuel cell components 15 years ago. Eight years ago, we began designing cell connectors for lithium-ion batteries, and we now supply complete battery modules. We have also added lightweight bodywork components to our portfolio. The lower your weight, the more energy-efficient you are, whether you are

driving a car fitted with a combustion engine or an electric vehicle. That's why I am not afraid of the transition that lies ahead, even if it is coming a lot faster than we anticipated just three years ago.

SCHMITT — Weight is a crucial factor in our sport, too. The rules state that lighter skiers have to use shorter skis. This leaves them with a smaller surface to generate lift. Even so, there is an advantage. Newly developed ski bindings have made a difference, as they allow the jumper to assume flight positions that are more favorable in aerodynamic terms. Overall, however, the rules have become much stricter over the last few decades and there is less regulatory leeway.

WOLF — That applies to us, too. Stricter limits on average fleet CO₂ emissions put car makers under greater pressure to sell as many electric vehicles as possible very quickly, especially given that the market share of diesels is still declining. The limits currently being discussed for 2025 and 2030 cannot be achieved without a significant proportion of CO₂-free drive concepts.

The automotive industry faces some huge changes. The real challenge lies in preparing a company so that it is ready to embrace those changes in good time.«

Dr. Stefan Wolf,
CEO of ElringKlinger AG

SCHMITT — Is everyone aware of the implications of the jump you are making?

WOLF — Yes. The real challenge lies in preparing a company that has a very successful history as a supplier for combustion engines so that it is ready to embrace those changes in good time. Of course, you also have to take your workforce with you. We have managed to do that at ElringKlinger, not only through technical training but also by communicating openly and highlighting the opportunities that new vehicle drive systems offer us.

SCHMITT — If you want to succeed, you just have to adapt to conditions that you cannot change. For instance, every ski jumper develops his or her own style over the years. If your particular style benefits from a strong front wind, you still have to be able to deliver a great performance with the wind behind you. The main thing is, when you are jumping you have to be able to respond to the specific situation. Sometimes you jump, and you don't know exactly what to expect when you are in the air. That's also an essential element of good preparation. You need to weigh up the risks in advance.

WOLF — So what role does the team play during the preparatory phase?

SCHMITT — If you look at the top of the global rankings, you can see that the best performances often come from certain teams, even though it is an individual sport. That is because ski jumpers train as part of a team throughout the year. To give you an example, for many years I used to spend every day on the ski jumps here in Hinterzarten with fellow ski jumper Sven Hannawald. We pushed each other to perform at our very best.





WOLF — You're right, and of course when you put a team together you benefit from their combined know-how. At the end of last year, for example, we concluded a cooperation agreement with Chengfei Integration Technology, an experienced Chinese manufacturer of battery cells. As a result, we can now offer our customers in China complete battery modules. Electromobility will evolve faster in China – the biggest car market in the world by a long way – than anywhere else. Together with our partner, we are ready for that impending jump – and in China it won't be long – into a new world of vehicle drive systems.

SCHMITT — The jump really is the crucial moment. In our case, we have to switch within 250 milliseconds from the downhill position that you adopt on the ramp to pick up as much speed as possible into the ideal flight position. To do that, you need supreme concentration and body control. While you can make some adjustments during the jump, they have to be really fast and intuitive. After all, one has to bear in mind that the jump is judged not only on your distance. Almost half the marks go for your position during flight and landing.

WOLF — Position is not really relevant in our case, but distance is certainly crucial. If you land short, you won't survive very long in the automotive industry, given the current pace of change. The pressures on us are enormous. At the moment, the

You have to check carefully that you have put everything in place that needs to be there for you to succeed. That goes for ski jumping or the world of business.«

Martin Schmitt,
Former international ski jumper



market share of electric vehicles is quite low, but it is climbing rapidly. The most important thing is that our customers are now developing cars for large-scale production from 2020 onwards, and we have already been designated as a supplier for some of the platforms. Our aim is to generate up to 25% of our sales from the promising fields of structural lightweighting and e-mobility over the next decade. If we land short of our target, we won't be able to achieve that.

SCHMITT — While you're in the air, you don't know exactly where you are going to land, especially on the large ramps, and a lot can happen over the last third of your jump. The trick is to find the right moment and to keep your balance.

WOLF — We will certainly try to do that. In any case, we have made all the preparations we can to make sure the jump comes off. Thanks for the chat, Martin.

MARTIN SCHMITT

One Olympic Gold Medal, two Silver, and countless world championship victories. Martin Schmitt has an impressive record as a ski jumper. In 1991, at the age of 13, he joined the youth division of the German Skiing Association and quickly worked his way up into the ranks of international elite jumpers. Although he has now retired from active competition, he still knocks out top performances, completing a degree in sports science at the University of Leipzig with the best grades in his entire year. Martin now works in television and runs his own sports marketing agency.

FORE

The automotive industry is undergoing a period of great change, with an increasing focus on alternative drive technologies. While there are still relatively few electric cars on the roads, demand is growing slowly but surely. ElringKlinger has prepared itself with considerable foresight in anticipation of current and future industry requirements. Indeed, the company is one of just a few automotive suppliers to have already established a strong portfolio of innovative solutions covering every type of vehicle drive – the combustion engine, hybrid systems, and all-electric solutions.



SIGHT

30%

of all new vehicles in Europe should be equipped with an electric or other alternative drive system by the year 2030 according to EU Commission plans. The figure for 2017 was less than 6%.

The trend towards sustainable mobility is already growing stronger, as shown by the number of new car registrations in the EU. At 852,933, the total for 2017 was up 40% on the previous year.



CONVENTIONAL COMBUSTION ENGINE

ENGINE PRODUCTS



Cylinder-head gaskets are crucial to the safe and cost-efficient operation of combustion engines, preventing any leakage of combustion gases, engine coolant, or oil. ElringKlinger has the right sealing system for every type of engine and for both cars and commercial vehicles.

PORTFOLIO

- Cylinder-head gaskets
- Sealing systems
- Thermal and acoustic shielding systems
- Lightweight plastic assemblies
- Deep-drawn and topographic housing assemblies
- Plastic components
- Development services



ElringKlinger is the world's leading supplier of cylinder-head gaskets.

TRANSMISSION PRODUCTS



ElringKlinger supplies efficient and customized gasket solutions for vehicle engines, gearboxes, exhaust systems, and auxiliary units such as compressors and pumps. The materials and designs are perfectly adapted to meet specific operating conditions.

PORTFOLIO

- Sealing systems
- Thermal and acoustic shielding systems
- Lightweight plastic assemblies
- Deep-drawn and topographic housing assemblies
- Plastic components



ElringKlinger's sealing portfolio covers transmission, engine, and exhaust applications.

EXHAUST TRACT PRODUCTS



As a result of engine encapsulation, compact assemblies, minimal air circulation, catalyst technology, and exhaust turbochargers, the temperature in the engine compartment, vehicle underbody, and exhaust system can be very high. Manufacturers also have to meet rigorous acoustic shielding requirements, both outside the vehicle and inside. ElringKlinger offers outstanding product solutions for every operating scenario.

PORTFOLIO

- Sealing systems
- Thermal and acoustic shielding systems
- Plastic components



ElringKlinger produces thermal and acoustic shielding systems.

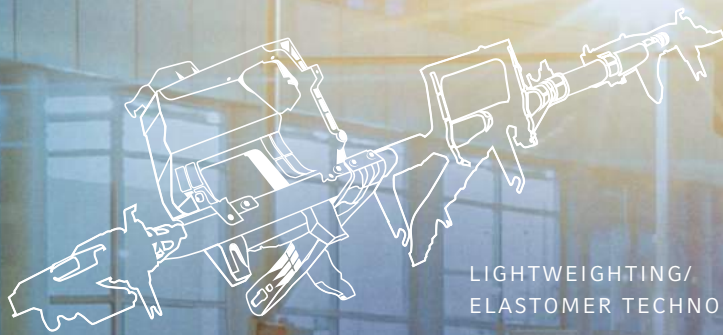

LIGHTWEIGHTING/
ELASTOMER TECHNOLOGY

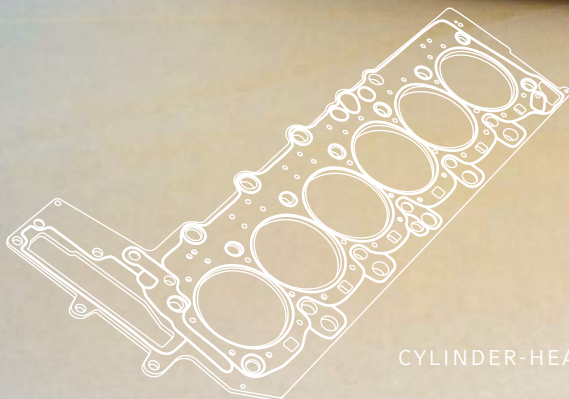

CYLINDER-HEAD GASKETS



SPECIALTY GASKETS

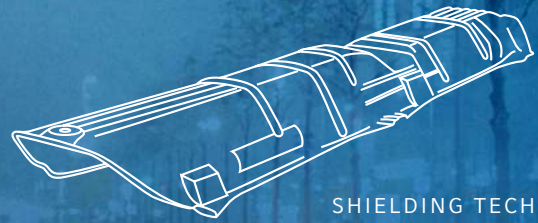

SHIELDING TECHNOLOGY

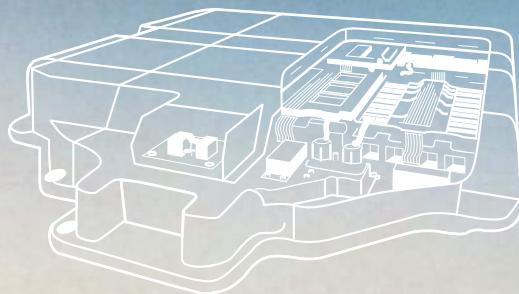

E-MOBILITY

ALTERNATIVE DRIVE TECHNOLOGIES

BATTERY COMPONENTS AND SYSTEMS



Efficient energy storage is crucial to the viability of electric vehicles. ElringKlinger has already scaled up its output of components for lithium-ion batteries (e.g., cell contact systems and module connectors) to series production level. In cooperation with its partners, the Group can also produce complete battery modules and systems as well as energy storage units.

PORTFOLIO

- Battery modules and energy storage units
- Battery components
 - Cell housings/connectors/contact systems
 - Module connectors
 - Plastic battery enclosures
 - Pressure-equalizing elements
- Development and testing
- Prototyping and production



ElringKlinger integrates customer-specific components into its battery modules as a complete solution.

FUEL CELL COMPONENTS AND STACKS



The great advantage of vehicles equipped with a fuel cell drive is their range. ElringKlinger has developed some very effective solutions in the area of fuel cell technology. Besides making its own stacks, for example, the company has patented several designs for metallic bipolar plates and plastic media modules that greatly simplify the fuel cell system.

PORTFOLIO

- PEM fuel cells
 - PEMFC stacks
 - Metallic bipolar plates
 - End and media modules
 - Casings
- Development and testing
- Prototyping and production



In addition to its wide range of components, ElringKlinger also offers complete fuel cell stacks.

POWERTRAIN MODULES AND SYSTEMS



In 2017, ElringKlinger established a strategic partnership with the engineering firm hofer in order to expand its electromobility business. hofer is widely recognized as a specialist in electric drive technology. Thanks to this additional know-how, ElringKlinger can now offer a wider range of products to help its customers bring their innovative drive concepts to the production stage.

PORTFOLIO

- System integration
- E-machines
- Power management electronics
- Control software
- Transmission
- Thermal management/cooling
- Safety concepts



ElringKlinger and hofer work together to produce electric drive units at small-scale series production level.



ELRINGKLINGER IS ACTIVELY HELPING TO SHAPE THE FUTURE OF ELECTROMOBILITY:

At its factory in Dettingen/Erms, the company has been making innovative cell contact systems and module connectors for various hybrid and battery-powered electric cars at series production level since 2011.

The automotive industry is currently in the throes of technological upheaval. Although demand for combustion engines is likely to increase in the short term and only start falling gradually from around 2021, the focus of both manufacturers and end customers is increasingly turning to alternative drive concepts that are designed to offer sustainable forms of mobility. Hybrid designs, which bring together a combustion engine and an electric drive, are viewed by industry experts merely as a bridging technology on the way towards fully electric vehicles. At present, the two main contenders for the drive system of the future are based on the battery and the fuel cell. Each offers certain inherent advantages. While battery-powered vehicles may have the edge in larger towns and cities where recharging points are more widely available, cars equipped with a fuel cell drive have a greater range, i.e., they can cover greater distances. ElringKlinger is right up there at the cutting edge. Having laid the foundations some years ago, the Group is now well prepared for the impending shift from combustion engines to alternative drive systems.

ElringKlinger's roots lie in sealing technology. The company produced its first gaskets way back in 1914, and to this day ElringKlinger has remained the world's leading supplier of cylinder-head gaskets. For this reason, the company is often seen as a traditional gasket maker. Today, however, there is a lot more to its portfolio. Over the years, always with an eye to the future, ElringKlinger has added many new products to its range. Alongside the company's traditional core business – sealing and shielding systems for engines, gearboxes, and exhausts – ElringKlinger has focused increasingly on lightweight construction as part of its wider strategy. This is regarded as a key technology within the automotive industry. Replacing metal components with lighter materials made of plastic or aluminum offers substantial benefits. In a vehicle with a combustion engine, lighter components translate into lower CO₂ emissions, while in an electric car they increase the range. ElringKlinger has built up years of experience in the field of lightweight construction

and supplies lightweight plastic components for both the vehicle body and the powertrain. All ElringKlinger products combine maximum functionality with minimal weight. What's more, the company's structural bodywork components can be used with any vehicle regardless of the drive system.

Another crucial element of the company's forward-looking portfolio is electromobility. ElringKlinger began to position itself in a range of technologies when they were still in their infancy. The company started working on fuel cell systems as long ago as 1999, and just a few years later it diversified into battery technology. In developing customized product solutions for the electromobility market, ElringKlinger was able to draw on its core expertise in the fields of metal forming, plastic injection molding, joining and coating technology, and automated assembly as well as on the skills of its in-house tooling facility. Besides individual components, ElringKlinger now offers complete low-temperature fuel cell stacks. Turning to battery technology, ElringKlinger began making various components for lithium-ion batteries at series production level some years ago, e.g., cell contact systems and module connectors. In cooperation with its partners, the company can also supply complete battery modules and systems as well as energy storage units. Furthermore, thanks to ElringKlinger's strategic purchase of a stake in the engineering firm hofer (Nürtingen, Germany), which specializes in electric drive technology, it has been able to greatly expand its e-mobility portfolio. As a result, the Group can now rightly boast proven expertise in the development and manufacture of alternative drive systems.

This revolution in vehicle drive technology involves far-reaching changes – for the automotive industry as a whole and for ElringKlinger of course. Having embraced a forward-looking strategy of concentrating on functional components, lightweight construction, and electromobility, the Group is transforming itself proactively from a mere component supplier to a provider of complete vehicle systems.

ElringKlinger's product portfolio – designed for the future

PRESENT

FUTURE

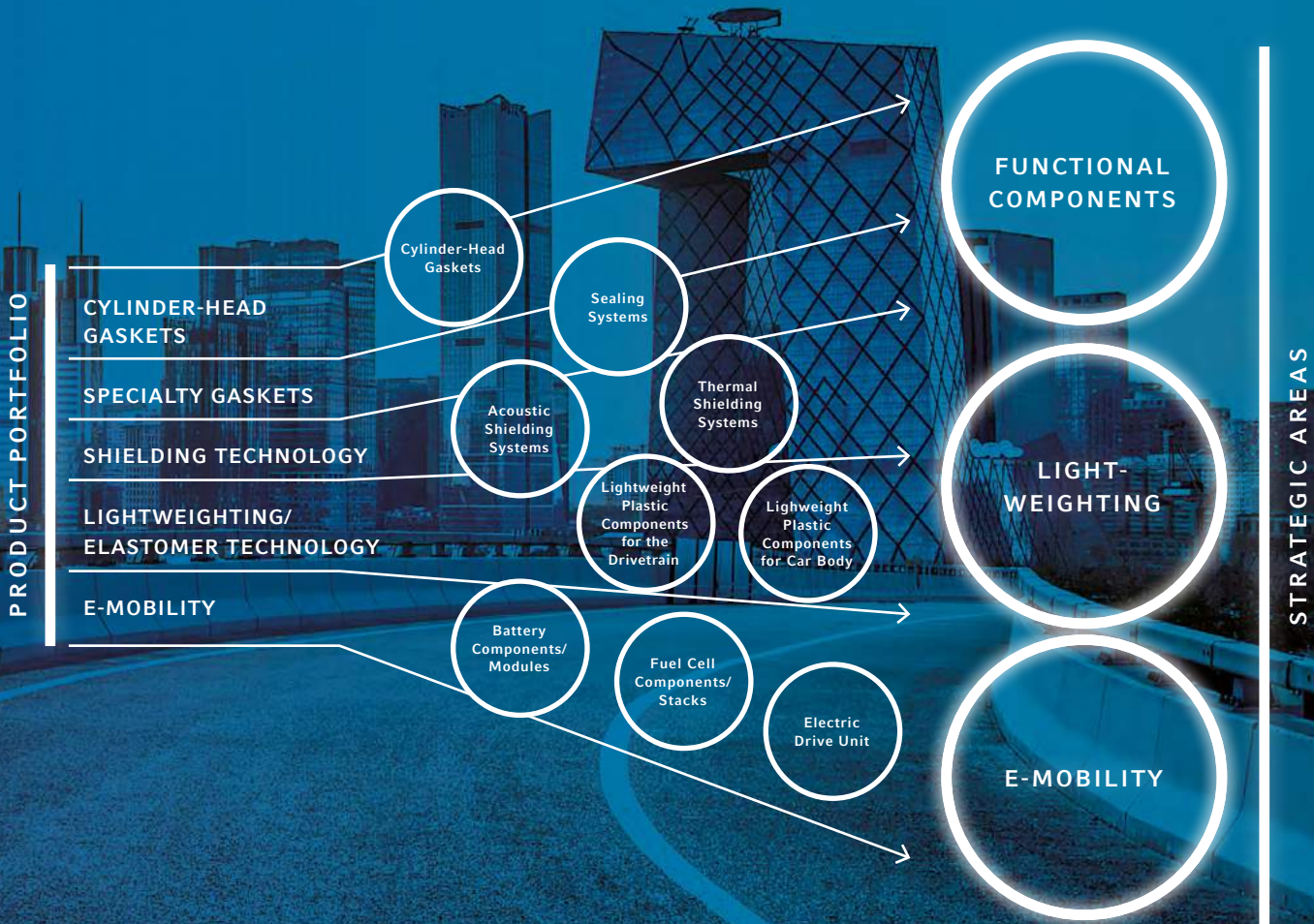

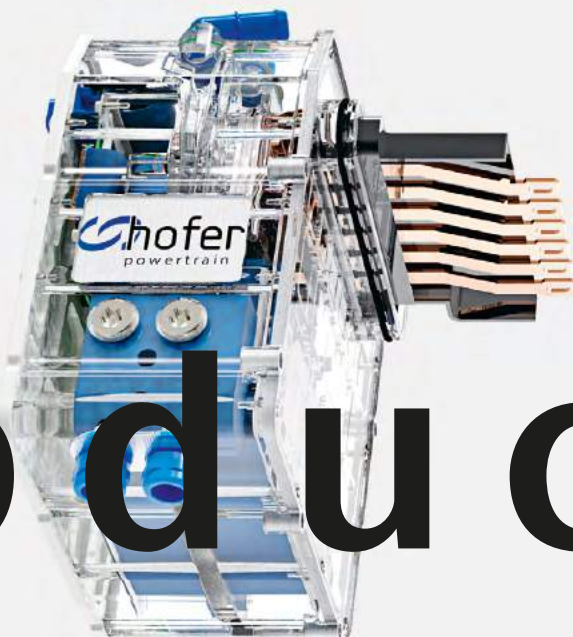

production

Electromobility is one of the keywords that comes up in any discussion about the future of the automotive industry. Yet many people are not aware of the fact that this technology was actually discovered a long time ago. The first electric car, known as the Trouvé Tricycle, could be found on the streets of Paris way back in 1881. It reached an impressive top speed of 12 km/h and had a range of up to 26 kilometers. Due to the success of the combustion engine, however, this alternative technology remained firmly on the shelf until its renaissance a hundred years later. Vehicles equipped with cutting-edge electric powertrains are enjoyable to drive, and most importantly they come with an extended range – a technological advance that is speeding up the process of transformation in the automotive industry.

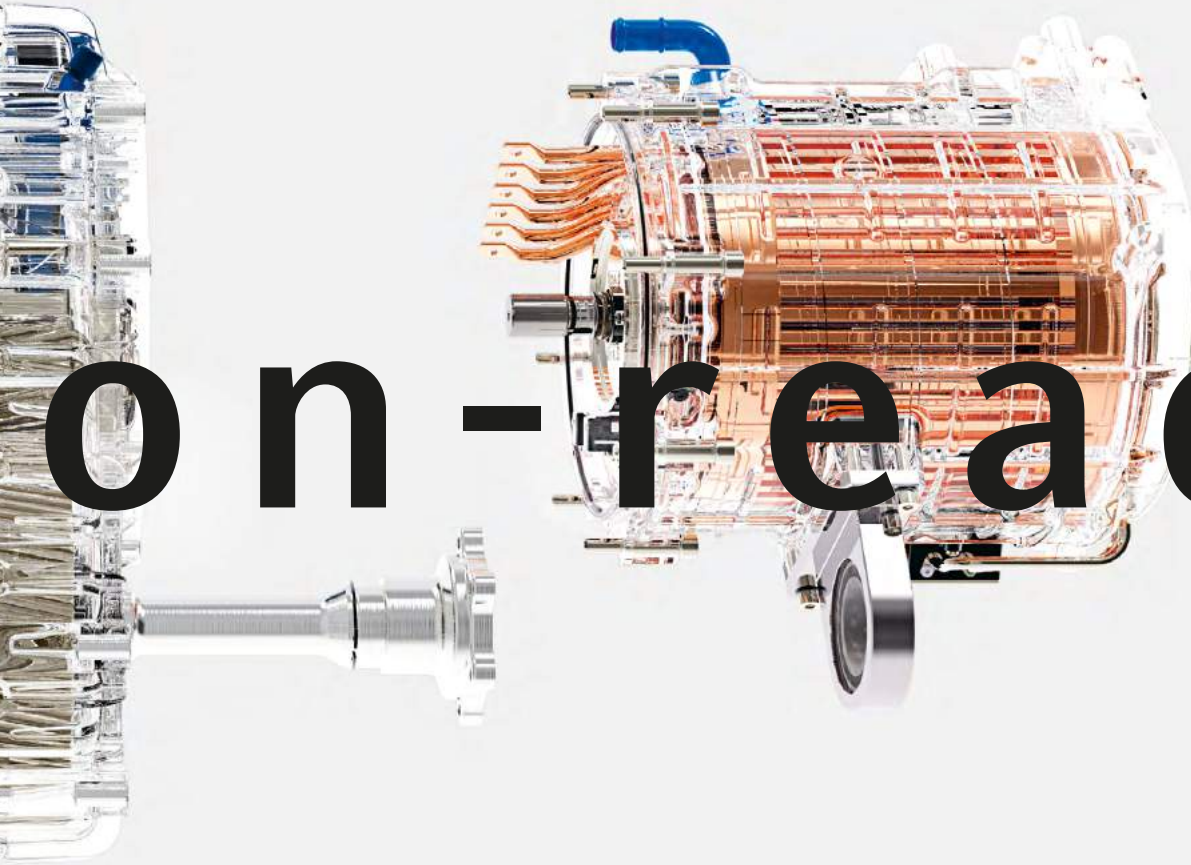

o n - r e a d y

Effective research and targeted development are paving the way for zero-emissions mobility. They underpin industry efforts to deliver efficient vehicle electrification and transform the entire automotive sector. The task facing companies in this industry is huge, as they not only have to adapt to these changes but must also drive the transformation of their products and processes.

Synergies can be harnessed wherever the whole is greater than the sum of its parts, as Aristotle put it. For this reason, partnerships are an important way of opening up new areas of expertise, combining the respective strengths of individual companies, and expanding the way we look at complex technical relationships. This was exactly the principle that led ElringKlinger to acquire a 27 % stake in hofer powertrain, Nürtingen, Germany, at the beginning of 2017. As a system developer and supplier, hofer powertrain is a highly innovative company that proactively shapes technological developments. It is a global ideas factory, whose expertise ranges from the traditional manual gearbox and modern double-clutch transmissions through to ground-breaking solutions for hybrid and electric vehicles. The company's activities range from the development of electric drive systems combining power management electronics, the transmission, and an electric engine all the way through to system integration. The company set its sights on advanced technologies such as these at an early stage and now supplies customized systems for high-end sports and luxury car applications. "Thanks to our technological edge and the successful field trials that we have already conducted, we believe we are seeing a new dimension of driving pleasure, and we want to integrate this experience as soon as

»Our vision is to deliver future technologies today, all ready for series production – that's what drives us every day.«

Wolfgang Stephan, Chief Technology Officer,
hofer powertrain



DR. HEINZ SCHÄFER
ELECTRIC DRIVE SYSTEM
DEVELOPER

Energy is mass times the speed of light squared. This physics equation is as famous as the person who first wrote it down in 1905 – Albert Einstein. The challenge we work on every day is to put that energy to efficient use on the roads.

4 seconds

To do that, we have already developed a complete system that allows us to accelerate an electrically operated vehicle from 0 to 100 km/h in just four seconds with hardly any noise. The car starts delivering torque immediately with no vibration, no interruption to power delivery, and regardless of rotational speed. In total, four electric motors are built into the vehicle – one for each of the wheels. The vehicle's on-road dynamics are improved by means of short drive shafts. That means all four wheels can be controlled separately in response to the specific driving situation.

To achieve perfection in an electric drive, all the systems must be logically dovetailed. For this reason, we also have the corresponding software technology to provide smart control of power flow.

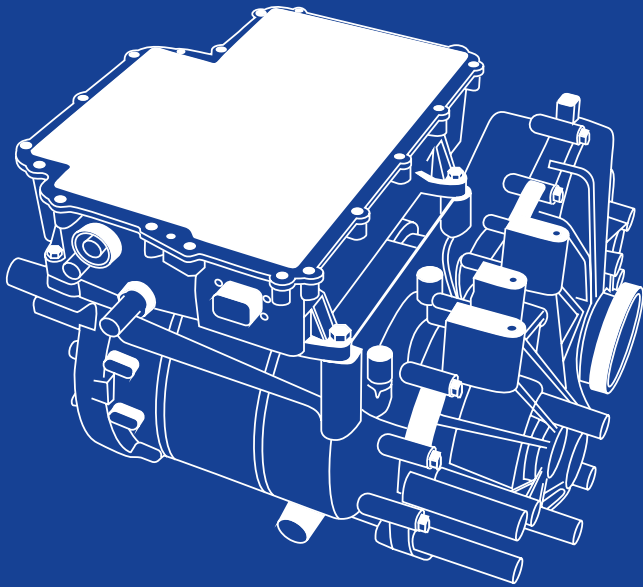

Mobility of the
future – ready for
series production.
Proven systems
expertise. Energetics
and dynamics in
perfection.

**ULRICH SAUTER,
GENERAL MANAGER OF HOFER
POWERTRAIN PRODUCTS GMBH
(NÜRTINGEN, GERMANY)**
hofer powertrain and ElringKlinger bring
together demonstrable development
expertise and methodological skills, extensive
materials know-how, many years of
production experience, and a proven track
record in multidisciplinary interaction –
a perfect match that will help us to success-
fully navigate the path towards electro-
mobility. Together, we have set ourselves
some very ambitious growth targets.

2 Production facilities

To achieve this, we have established a very close partnership based on trust. Our first step will be to prepare our current assembly line in Germany, which so far has only handled small-scale orders, so that it can deal with larger production volumes. We are also setting up a production facility in the UK. The second step will be to penetrate the Chinese and North American markets. At the same time, drawing on the ElringKlinger Group's manufacturing strength, we plan to keep expanding the division's vertical range of manufacture and harness additional synergies.



Effective research and targeted development are paving the way for zero-emissions mobility. They underpin industry efforts to deliver efficient vehicle electrification and transform the entire automotive sector. The task facing companies in this industry is huge, as they not only have to adapt to these changes but must also drive the transformation of their products and processes.

Synergies can be harnessed wherever the whole is greater than the sum of its parts, as Aristotle put it. For this reason, partnerships are an important way of opening up new areas of expertise, combining the respective strengths of individual companies, and expanding the way we look at complex technical relationships. This was exactly the principle that led ElringKlinger to acquire a 27 % stake in hofer powertrain, Nürtingen, Germany, at the beginning of 2017. As a system developer and supplier, hofer powertrain is a highly innovative company that proactively shapes technological developments. It is a global ideas factory, whose expertise ranges from the traditional manual gearbox and modern double-clutch transmissions through to ground-breaking solutions for hybrid and electric vehicles. The company's activities range from the development of electric drive systems combining power management electronics, the transmission, and an electric engine all the way through to system integration. The company set its sights on advanced technologies such as these at an early stage and now supplies customized systems for high-end sports and luxury car applications. "Thanks to our technological edge and the successful field trials that we have already conducted, we believe we are seeing a new dimension of driving pleasure, and we want to integrate this experience as soon as

»Our vision is to deliver future technologies today, all ready for series production – that's what drives us every day.«

Wolfgang Stephan, Chief Technology Officer,
hofer powertrain

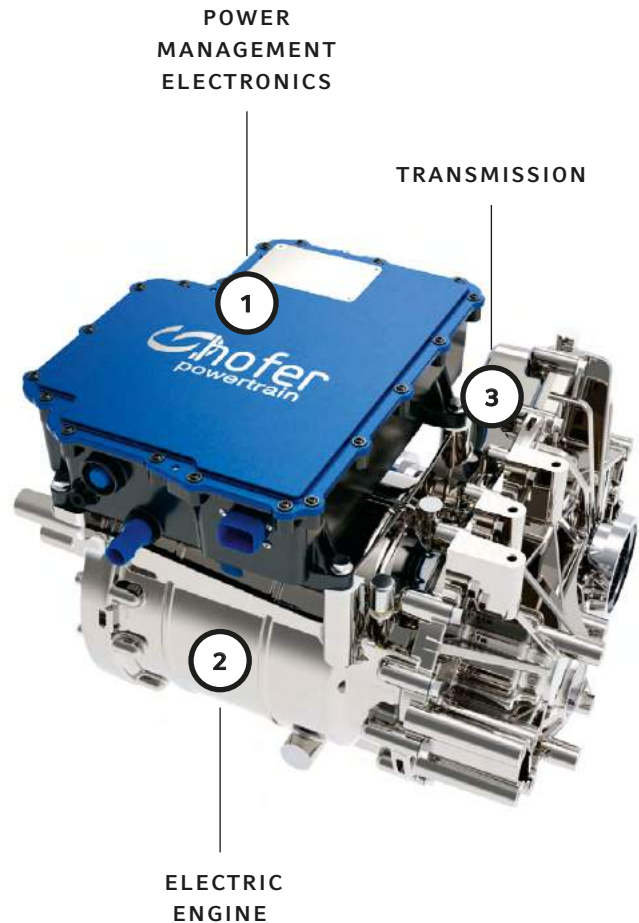

ELECTRIC DRIVE UNIT

hofer powertrain already supplies production-ready electric drive units. That includes customized solutions for high-end sports and luxury car applications. The electric drive unit includes ① the power management electronics, which provide overall drive control and convert the direct current in the high-performance battery into three-phase AC power. ② The electric engine then converts this electrical energy into mechanical energy. The job of transferring the torque to the wheels is performed by the ③ transmission.

»By combining know-how with development and production expertise, we are evolving together as a provider of complete e-mobility solutions.«

Armin Diez, Vice President New Business Areas,
ElringKlinger AG

possible into other models of vehicles,” explains Wolfgang Stephan, Chief Technology Officer at hofer powertrain.

In the past, due to the relatively modest volumes of the orders involved, the company relied on a relatively small manufacturing workshop to translate its development ideas into products. However, hofer powertrain’s expertise and success have placed increased demands on operations. At series production level, you need greater standardization and automation, and there are new technical demands. As development cycles become shorter and shorter, the success of an order depends crucially on being ready for series production when the customer needs your product. For this reason, the overall time frame has to be planned systematically in advance. The organizational framework and main processes are specified in a multi-project plan. The early involvement of industrialization experts from the production subsidiary hofer powertrain products GmbH is crucial, as they are responsible for process development and for creating the infrastructure needed to optimize series production from a cost perspective. By way of example, a modular development structure is a critical advantage. The more an overall system can be structured in the form of modules, the more its assembly processes can be standardized and existing production facilities used for other projects. “Working together, we were able to lay the main organizational foundations within both companies in a very short time – even before the market for purely electric vehicles grew to any significant size,” explains Armin Diez, who heads up ElringKlinger’s New Business Areas unit. “That means there are no longer any obstacles to our working together on complex orders.”

ULRICH SAUTER,
GENERAL MANAGER OF HOFER
POWERTRAIN PRODUCTS GMBH
(NÜRTINGEN, GERMANY)
hofer powertrain and ElringKlinger bring together demonstrable development expertise and methodological skills, extensive materials know-how, many years of production experience, and a proven track record in multidisciplinary interaction – a perfect match that will help us to successfully navigate the path towards electro-mobility. Together, we have set ourselves some very ambitious growth targets.

2 Production facilities

To achieve this, we have established a very close partnership based on trust. Our first step will be to prepare our current assembly line in Germany, which so far has only handled small-scale orders, so that it can deal with larger production volumes. We are also setting up a production facility in the UK. The second step will be to penetrate the Chinese and North American markets. At the same time, drawing on the ElringKlinger Group’s manufacturing strength, we plan to keep expanding the division’s vertical range of manufacture and harness additional synergies.



Enlightened

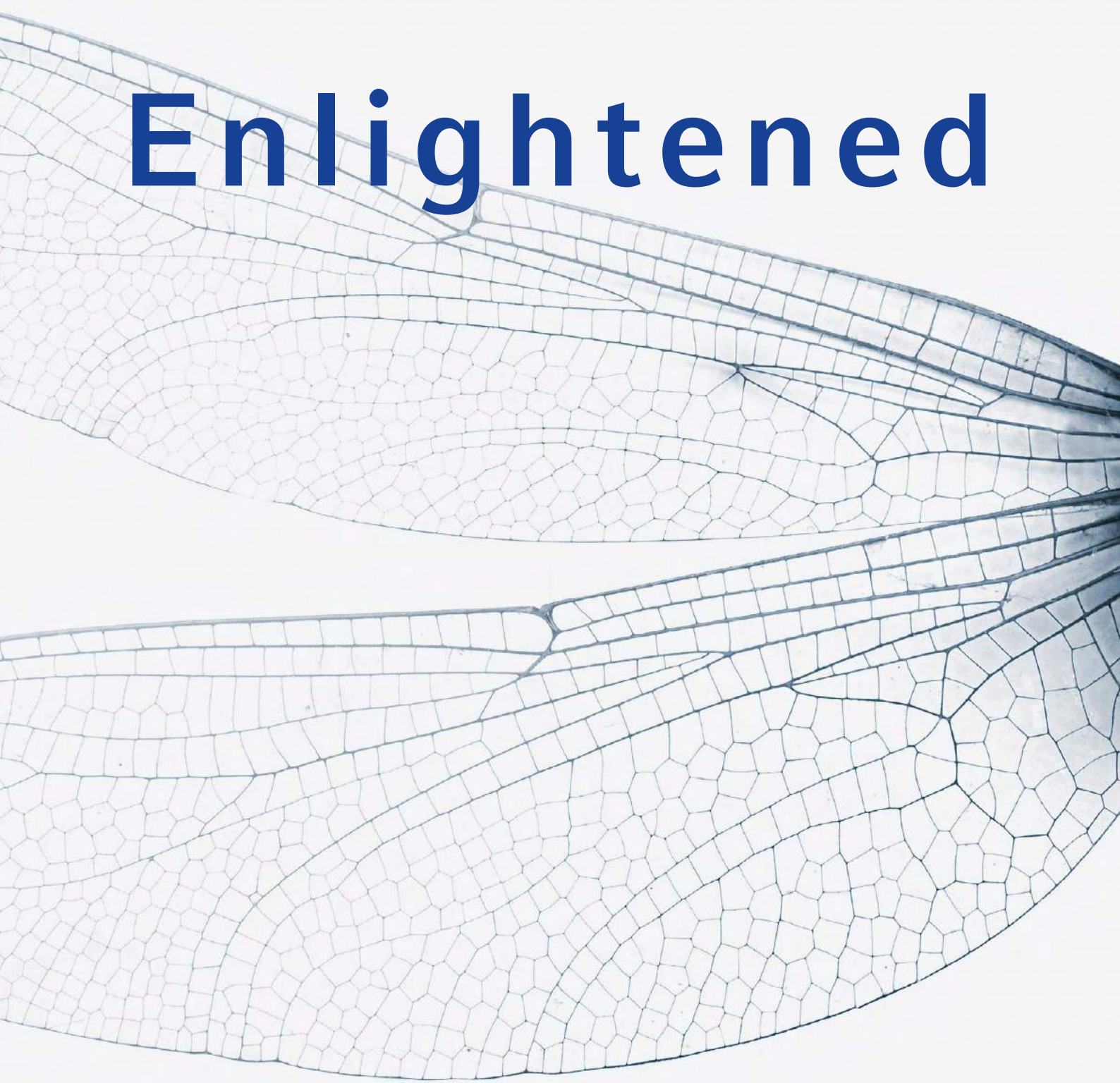

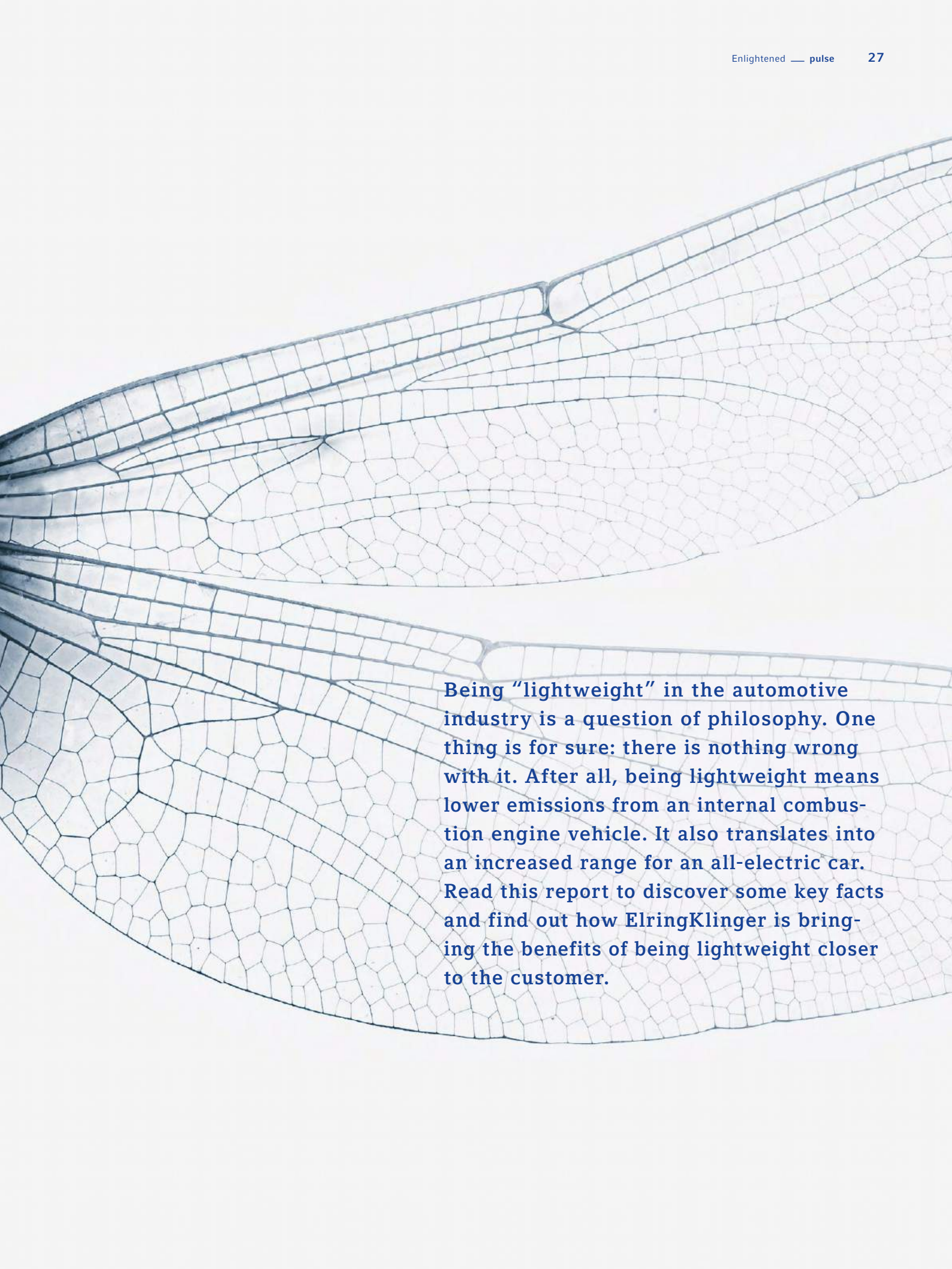

Being “lightweight” in the automotive industry is a question of philosophy. One thing is for sure: there is nothing wrong with it. After all, being lightweight means lower emissions from an internal combustion engine vehicle. It also translates into an increased range for an all-electric car. Read this report to discover some key facts and find out how ElringKlinger is bringing the benefits of being lightweight closer to the customer.

Lightweighting is particularly popular among customers. This applies equally to established producers and to new market players, such as those in California. ElringKlinger has built up significant expertise in this area and is also successful marketing its lightweight products among its customers on the ground, as several high-volume orders demonstrate.



ElringKlinger's Simon Knoll is working the US West Coast.

When Simon Knoll makes his way to his office in the morning, the sun is only just beginning to rise over the summits of Mission Peak. Life here in Fremont on San Francisco Bay has a lot to be said for it, and the mountains of the nature reserve in the eastern section of the city are as much a part of that as the ocean to the west. But Knoll only ever has time to admire them in the evenings and on weekends. Right from the early hours of the morning, his attention is focused solely on his sales activities. After all, his colleagues back in his native Germany have already been up and about for several hours and have left him a brimming inbox, as usual. The time difference is nine hours.

As ElringKlinger's man on the ground, Simon Knoll is responsible for reaching out to the numerous next-generation car makers gradually setting up shop here in California. Many of them have names that are not as familiar – even to industry insiders – as those of the traditional manufacturers or the top dogs among the providers of electric vehicles.

The existing and potential customers with whom Knoll is cultivating relationships also include those who, rather than focusing solely on electric drives, are already busy integrating autonomous driving and connectivity into the models they are developing. This is enabling them to complete the whole "triple jump" facing the automotive industry all in one go. First, the car of the future will be emission-neutral; second, the driver will no longer actually be doing the driving, or at least not all of the time; and third, the vehicle will be permanently online to optimize traffic control and onboard entertainment for the people inside. Impossible? Not for the visionaries of Silicon Valley.

"You really sense a different mentality here – full of pioneering spirit, openness, and enthusiasm," Simon Knoll says. "Development cycles are much shorter than used to be the case in the industry. Rather than everything hinging on whether or not something is possible, it's only ever a question of 'how.'" Knoll knows what he is talking about. He cultivates close links with his new customers, because long-term business relationships with the "new players" are as much a part of ElringKlinger's philosophy as a trust-based working relationship with the traditional providers.

Developing and strengthening new global contacts is the main job of the sales team led by Günther Fermenta, who manages relations with these "new player" customers from his base in Germany. He makes best use of his global sales experience with the Big Three from Detroit as well as his many years spent working in Asia to introduce this new clientele to the whole of ElringKlinger's product range. This sees him make regular trips to Silicon Valley, where he joins Simon Knoll to hold meetings with customers. "And lightweighting is an unquestionably important issue, because the new players know precisely what benefits they can get from having less weight and more functionality," Fermenta says. "And then there's the fact that the hierarchies are flat and the decision-making channels are short. This means everything happens much faster – in development, in the order-to-market phase, or in integrating innovations, such as autonomous driving. Many new providers are emerging, bringing us many new areas of application."

Fermenta and his team have already convinced a major US manufacturer of the benefits of ElringKlinger's lightweight structural components. The order is worth more than hundred million euros and series production is now underway. The Group has already

67%

of those asked in a VDI study believe that the kinds of fiber-reinforced composites that ElringKlinger offers harbor the greatest potential for growth in series production – well ahead of magnesium (19 %) and aluminum (14 %).

SIMON KNOLL**KEY ACCOUNT MANAGER NEW OE**

After writing his Master's thesis on battery modules, the engineer and business administration graduate devoted his attention to lightweighting, another hot topic for the future at ElringKlinger. He has been the company's local sales representative for the new automotive manufacturers on the US West Coast since 2016.

GÜNTHER FERMENTA**DIRECTOR SALES GLOBAL ACCOUNT NEW OE**

The sales professional has worked in the automotive supply industry for an impressive 30 years, a full 26 of them at ElringKlinger. A graduate in business administration, he spent a total of ten years as Director of Sales for the key accounts of General Motors and FiatChrysler plus 14 years as Regional Director in Asia. Business involving the new automotive manufacturers is being expanded across the world under his leadership.

PHILIPP RUEZ**GLOBAL BUSINESS DEVELOPMENT MANAGER LIGHTWEIGHTING**

Holder of a degree in business administration as well as an MBA, he joined ElringKlinger when it acquired the toolmaker Hummel-Formen GmbH. Together with the Lightweighting/Elastomer Technology division, he develops new product ideas in the structural lightweighting segment and assesses them for marketability.



Philipp Ruez is expanding ElringKlinger's portfolio of structural lightweighting products.



Günther Fermenta heads up the sales team for the new automotive manufacturers.

won its next large-scale order, too. "We are in advanced negotiations with other manufacturers as well. Our list of development projects is a long one," Fermenta adds. "More orders will follow on the back of that."

When it comes to analyzing their customers' needs and providing solutions that are relevant to them, the two men receive support from the Group's headquarters in Dettingen/Erms, the base for Philipp Ruez, who acts as the "nerve center" for sales related to lightweighting. He is responsible for pooling customer requirements, developing new product ideas, and assessing them for marketability. Ruez firmly believes that more applications will emerge in addition to the Group's first batch of structural lightweight components – its cockpit cross-car beam, front-end carrier, and door module carrier. "In the next few years, our sales activities will focus on marketing the structural components that we've already launched. However, we've still got many more ideas on how we can use our unique technologies in lightweighting in ways that make sense and benefit the customer," Ruez explains.

ElringKlinger's USP for structural components is its combination of production process and material expertise that enables a basic material to be reshaped and plastic injection-molded onto a component in a single production step. "This highly innovative technique gives the customer three advantages over their conventional options: they can save weight, and the structural component can hold more features. Something that doesn't require an extra process step, incidentally," Ruez stresses. "And, last but not least, our products are usually fully recyclable."

So, could he reveal one of the new ideas to us, we ask him. Ruez, however, is reticent: "I don't want to give too much away," the business development manager says. "But you'll find structures that lend themselves to lightweighting in a vehicle's body frame as well as in its interior or trunk. And you don't have to stop at the automotive industry either." He feels sure that there is still great potential for arousing customer interest, because lightweighting allows energy to be used efficiently. After all, being lightweight is a question of philosophy.

Lightweighting is one of ElringKlinger's strategic areas of business. While lightweight engine components have been part of its product portfolio for nearly 20 years, the Group has grown its expertise to include lightweight structural components as well in the past five years or so. Further revenue growth is expected in this area over the next few years.



The Group brings its extensive materials, process, and manufacturing expertise to bear with lightweighting solutions for bodywork. This innovative series of polymer/metal hybrid products also includes the front-end carrier, which is already in series production.



OIL PANS
ElringKlinger's range of lightweight products also includes engine components such as oil pans.



OVER

€100 million

in revenue will be generated by 2024 from an order for door module carriers made from so-called organo sheets. Besides saving on weight, these also allow more features to be integrated.

THERE ARE NOW

4

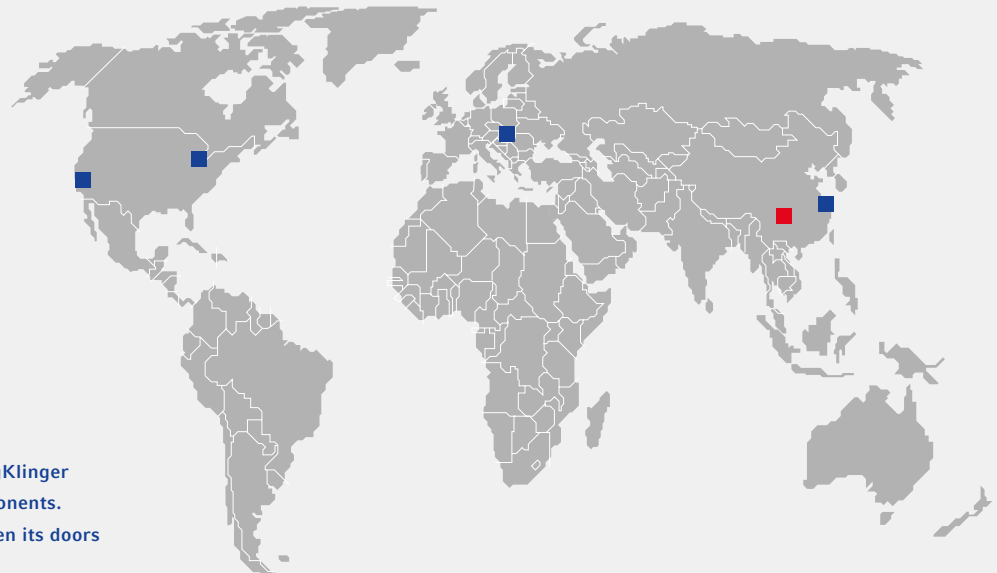

sites around the world at which ElringKlinger produces lightweight structural components. The fifth, Chongqing in China, will open its doors in 2018.

UP TO



40%

in weight savings can be achieved by a hybrid cockpit cross-car beam from ElringKlinger.

No.1

in the commercial vehicle segment: ElringKlinger is the world leader in polyamide oil pans. These pans weigh between 30% and 50% less than deep-drawn steel pans and die-cast aluminum ones.

10

CYLINDER-HEAD COVERS ROLL OFF ELRINGKLINGER'S GLOBAL PRODUCTION LINES EVERY YEAR.



million

Nothing can happen without tools: Hummel-Formen has been part of the ElringKlinger Group since 2011. The toolmaker for injection molds facilitates the creation of complex geometries and thus is instrumental in enabling hybrid products such as cockpit cross-car beams and door module carriers to be made.

Revenue share of Hummel-Formen tools sold for

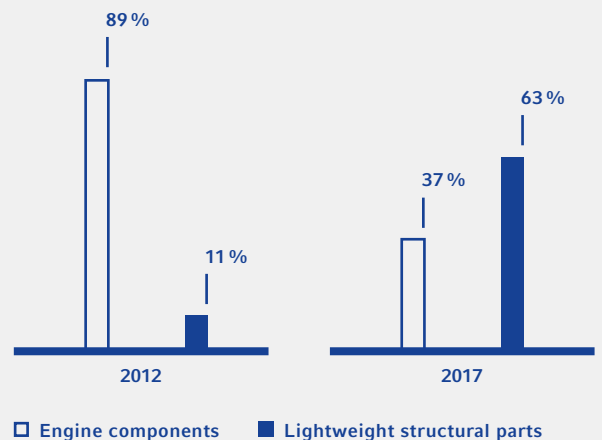

P A C E S E T T E R S

"WHEN IT COMES TO ALTERNATIVE DRIVE SYSTEMS, THE SCALE OF CONTRIBUTIONS MADE BY MANUFACTURERS AND SUPPLIERS TO THE VALUE CHAIN IS SHIFTING. I FIND IT VERY EXCITING TO BE DEALING WITH OEMS ON AN EQUAL FOOTING AND WINNING THEM AS CUSTOMERS ON THE STRENGTH OF OUR TECHNICALLY OUTSTANDING PRODUCTS."

Whenever Development Engineer Stefan Hemmer evaluates fuel cell module trials in the lab, his priority is to push on PEM fuel cell technology as the basis for sustainable mobility. Throughout the complete development process, he is in close contact with the customer to ensure that the module and the customer's system work together perfectly. What drives him? "I work in a highly motivated team with a clear objective: to harness the enormous potential of the fuel cell and bring it to full-scale production within our company."

Stefan Hemmer, ElringKlinger AG, Dettingen/Erms, Germany

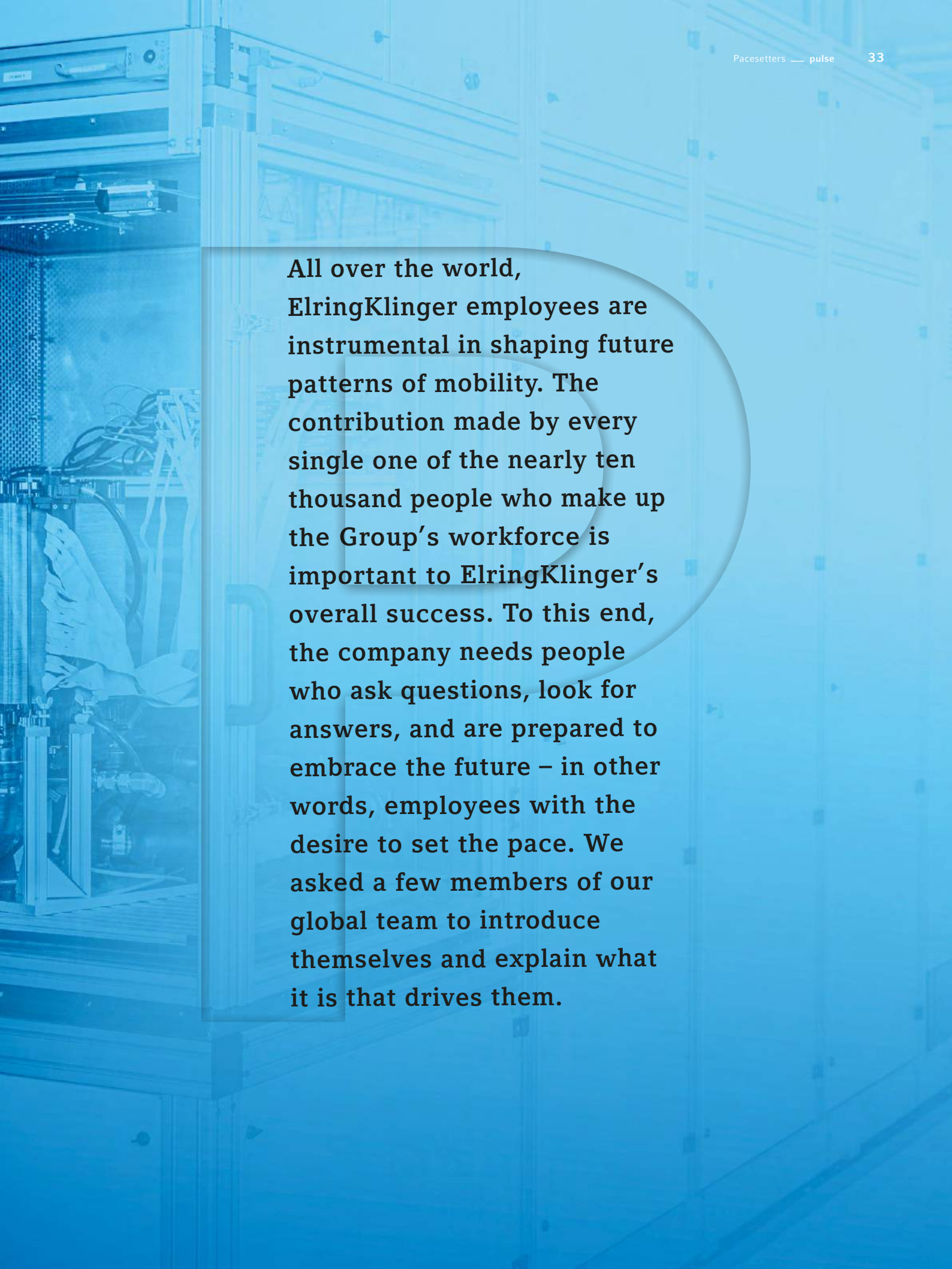

All over the world, ElringKlinger employees are instrumental in shaping future patterns of mobility. The contribution made by every single one of the nearly ten thousand people who make up the Group's workforce is important to ElringKlinger's overall success. To this end, the company needs people who ask questions, look for answers, and are prepared to embrace the future – in other words, employees with the desire to set the pace. We asked a few members of our global team to introduce themselves and explain what it is that drives them.



“CHINA IS A VERY BIG MARKET FOR THE MOBILITY INDUSTRY, AND THERE’S NO DOUBT FULL-SCALE LEGAL SUPPORT WILL BE REQUIRED. SO I AM PROUD THAT I CAN CONTRIBUTE TO OUR BUSINESS OF THE FUTURE.”

For her role as Legal Counsel, Vivian Yang needs in-depth knowledge of Chinese law. Besides supporting our production centers in China, she also advises on global projects. For example, she helped to draft the framework agreement between ElringKlinger and the Chinese firm Chengfei Integration Technology relating to battery technology. So what drives Vivian? “I spend a lot of my time conducting research. Because the automotive industry is going through a period of great change. This throws up all sorts of new and interesting issues that need to be addressed from a legal perspective.”

Vivian Yang, ElringKlinger China Ltd., Suzhou, China

“TODAY, PROCESSES THAT USED TO WORK PERFECTLY WELL UNTIL YESTERDAY NEED TO BE ADAPTED. THE CURRENT TRANSITION OF MOBILITY IS REFLECTED IN MY DAILY WORK.”

Program Manager Jochen Stanger certainly saw a few changes in 2017. When ElringKlinger bought a stake in the hofer Group at the beginning of the year, he was given overall project management responsibility for the development and industrialization of an electric powertrain. His role involves defining processes, drawing up new standards, and introducing them in project work for hofer powertrain products. What is it that motivates him? “I can set a lot of things in motion, both at project level and by designing new processes. With this in mind, I’m happy to take on responsibility.”

Jochen Stanger, hofer powertrain products GmbH, Nürtingen, Germany





"IN MY EARLY EXPERIENCE, PROJECTS WERE DONE BY THE BOOK WITH DATES THAT WERE METICULOUSLY PLANNED. TODAY, PROJECTS PROGRESS IN REAL TIME, AND THE RESOURCES HAVE TO BE AT HAND WHEN THEY ARE NEEDED."

Right from the start, Myrna Sotelo Moreno was involved in the production of cockpit cross-car beams, which entered series production at our Californian factory in 2017. As Quality and Environmental Manager, her responsibilities are wide-ranging. She oversees audits, produces documentation, sets up new quality control processes, and arranges the technical equipment needed to conduct quality checks. For Myrna, the most effective tools she has are her flexibility and passion for achieving top quality. What motivates her? "ElringKlinger allows me to be creative."

Myrna Sotelo Moreno, ElringKlinger Silicon Valley, Inc., Fremont, USA

FUEL CELL

The goal of the development project on which engineer Stefan Hemmer was working in 2017 was to increase the range of battery-powered electric buses by using fuel cell technology. Stefan and his team developed a highly integrated media module made of injection-molded plastic. The module is an important component that supplies the functional units of the fuel cell stack with hydrogen, oxygen, and coolant. It also acts as the interface to the vehicle system environment that takes up the supply of electricity. Tests will be conducted in 2018 in electric buses to assess how well the fuel cell system performs as a range extender.

BATTERY

The framework agreement that Vivian Yang helped to draft for ElringKlinger and the Chinese cell manufacturer Chengfei Integration Technology (CITC) covers the development, production, and distribution of lithium-ion battery modules. Vivian also acted as a bridge in communications between the German parent company and ElringKlinger's Chinese partner, especially when it came to merging the different requirements of German and Chinese law into a single contract.

ELECTRIC DRIVETRAIN

The sheer complexity involved in the task of combining an electric motor, power management electronics, and the transmission into an efficient drive system presented Jochen Stanger with some new challenges in 2017. As overall project manager for the development and industrialization of an electric drive system, he coordinated five teams of experts from the hofer Group's engineering pool, each of which specializes in a particular product area. At the same time, he had to liaise with the customer (a manufacturer of pure electric vehicles), make future production arrangements, and establish any relevant new standards.

LIGHTWEIGHTING

In 2017, Myrna Sotelo Moreno coordinated the installation and commissioning of a CMM system designed to check the quality of cockpit cross-car beams – hybrid body components made of aluminum and plastic – at 571 different measuring points. When these are all met, the lightweight components leave ElringKlinger's factory in Fremont (USA) for delivery to a manufacturer of next-generation vehicles.

4

CUTTING-EDGE PROJECTS

A
—
U
E



L
R
N
R

L
O
D

Battery or fuel cell? In the race to establish tomorrow's dominant vehicle drive technology, hydrogen-powered fuel cells are drawing more and more attention. ElringKlinger's experts give an insight into the potential of this technology and explain why the two concepts are not mutually exclusive. Outside specialists also provide their view of current developments in a series of short statements.

The idea is not a new one. When the chemist Christian Friedrich Schönbein immersed two platinum electrodes into sulfuric acid in 1838 and introduced hydrogen and oxygen as reactants, he made a ground-breaking discovery: there was a flow of electricity. In doing so, he laid the foundation for the first fuel cell that was built later by the British physical chemist Sir William Robert Grove. Grove called it a "gaseous voltaic battery" and went down in history as the father of the fuel cell. Unfortunately, the initial wave of enthusiasm soon ebbed away because inventions such as the dynamo generated much more electricity at the time. It was not until the mid-20th century that the use of fuel cells in submarines and space capsules breathed new life into the emission-free technology. In terms of broader applications, however, the fuel cell remained firmly on the shelf.

Until today, that is. The world has moved on at a frantic pace, and climate change has presented us with the huge challenge of reducing our CO₂ emissions. There is a broad consensus among experts that global climate objectives can only be achieved if all the different energy

sectors – electricity, heating, and transport – become more efficient. Hydrogen is a key component in this transformation. The simplest of all elements is a real all-rounder. It can be used not only to produce electricity in a fuel cell but can also be burnt in the same way as a conventional fuel or used as a storage medium for different forms of energy. Almost 180 years after it was first discovered by Schönbein, the term "cold combustion" is now on everyone's lips.

This development involves a major upheaval for the automotive industry, which is pinning its hopes of zero-emissions mobility on alternative drives such as battery and fuel cell systems. While battery-powered electric vehicles primarily make sense if you are only driving short distances, they face various challenges when it comes to longer distances. Their range is limited: under real-world driving conditions, most purely battery-powered electric cars can only manage 400 kilometers and then need to be recharged for several hours. Even fast recharging stations take half an hour to bring the battery back up to a nearly full charge – not to mention the fact that there is currently no widely available recharging infrastructure.

On a roll: fuel cell development is advancing rapidly.



1838

FUEL CELL

The physicist and chemist Christian Friedrich Schönbein discovers the principle of the fuel cell. Schönbein was born in Metzingen, a stone's throw from ElringKlinger AG's headquarters.



1963

SATELLITE

Fuel cells are used on board a satellite for the first time. The technology is later incorporated into space capsules.



1993

BUS

The first bus is equipped with fuel cells for demonstration purposes.



2007

CAR

A Japanese manufacturer unveils the first fuel cell car to enter series production.



2008

FORKLIFT

A forklift powered by fuel cells is tested in the port of Hamburg.



2017

TRUCK

Several manufacturers announce plans for new trucks equipped with fuel cells.



Within the automotive industry, fuel cells are regarded as the only viable complement to battery technology, and for good reason. Batteries merely store energy, whereas fuel cells can actually convert that energy. They convert hydrogen mainly into electrical energy, and the only waste product, water vapor, is perfectly harmless. Fuel cells – or to be more precise, proton-exchange membrane fuel cells (PEM fuel cells for short) – could therefore be the solution that provides us with clean mobility for the future.



DR. JÜRGEN KRAFT,
ELRINGKLINGER AG

»Fuel cells offer a high power density and are ideally suited for mobile applications. I am convinced that this technology will play a key role in the future of the automotive industry.«

So, is the fuel cell just hype, or is it a real alternative to the conventional combustion engine? Dr. Jürgen Kraft specializes in fuel cell technology and is convinced that it has a definite place in tomorrow's automotive world. As a physicist, he leads a team developing PEM fuel cell stacks at ElringKlinger, exploring the potential of fuel cells for broader industrialization. He is fully aware of the many benefits associated with fuel cells: "A vehicle equipped with PEM fuel cells can travel more than 500 kilometers, and refueling takes as little as two to five minutes." If the hydrogen is sourced from renewable energy, you have a completely pollution-free form of mobility. Another advantage is that the heat generated when the energy is converted can be used – in winter, for example – to keep the vehicle interior warm, therefore avoiding any reduction in the vehicle's range compared with battery-powered vehicles. There is a huge range of potential applications. Cars, buses, light commercial vehicles, trucks, trains, and warehouse vehicles such as forklifts are all predestined to be equipped with fuel cell drives.

With so many advantages, it is no wonder that car makers and suppliers such as ElringKlinger have been working on this highly promising technology for the last 20 years, overcoming challenges such as the development of robust tanks that can withstand pressures of up to 700 bar as well as those associated with crash safety and evaporation during long parking intervals. Numerous car makers have already developed early demonstration vehicles or prototypes with hydrogen drives. Some Japanese manufacturers are already producing fuel cell cars at series level, although they are very expensive due to the small numbers involved. Over the years, ElringKlinger has developed a great deal of experience in the field of fuel cell technology and now supplies its own stacks, metallic bipolar plates, and plastic media modules. For Jürgen Kraft, ElringKlinger has a major strategic advantage: "Our traditional core competences in metalworking and plastics processing as well as in the field of join-



DR. CHRISTOPHER HEBLING,
FRAUNHOFER INSTITUTE
FOR SOLAR ENERGY
SYSTEMS ISE

»Hydrogen is an important ingredient in the energy revolution. In car fuel cells, for example, it can be used to help achieve the twin goals of energy efficiency and zero-emissions mobility.«

ing, coating, and tooling technology can all be harnessed in the development of fuel cells."

The idea of using fuel cells as range extenders is particularly attractive. Depending on the system configuration, fuel cells could supply an electric engine directly with energy or recharge the battery. "That combines the best of both worlds – both batteries and fuel cells. You could then have a smaller battery, which would of course cost less, while the fuel cell can be operated at maximum efficiency," raves Jürgen Kraft.

Dr. Mohsine Zahid too believes it is no longer a question of “if” but “when” fuel cell drives will take off. He is responsible for developing the fuel cell business at ElringKlinger, a role that involves a great deal of travel all over the world. He is therefore very familiar with markets and customers: “For the moment, fuel cell cars are still a niche product, partly because there is as yet no national network of hydrogen refueling stations.” There are currently fewer than 100 in Germany, although the aim is to reach 400 by 2023. Nevertheless, he believes there is a great deal of interest in this revolutionary energy technology, especially in Asia,



DR. MOHSINE ZAHID,
ELRINGKLINGER AG

»The fuel cell technology has tremendously gained momentum over the last two years. At ElringKlinger, we are currently working on a wide range of development and grant-funded projects in this area.«

where he held a series of discussions last year with numerous potential customers. “Zero-emissions drive technology is really up there on the agenda in China,” he explains. “For that reason, tremendous effort is going into putting alternative drive vehicles on the roads.” Driven by very substantial government subsidies, many local buses in China’s cities are already equipped with fuel cell systems. Dr. Zahid believes that ElringKlinger’s up-front investments in the field of fuel cell technology in recent years will soon pay off. “Thanks to our long-established expertise, we are very much in demand as a partner. Our products have already proven their worth at series production level; our global production network is another advantage.”



PROF. DR. WERNER TILLMETZ,
CENTER FOR SOLAR
ENERGY AND HYDROGEN
RESEARCH (ZSW)

»Fuel cell cars are the ideal replacement for all those vehicles currently using diesel engines: from touring sedans designed for longer journeys through to local buses.«

There is every chance that fuel cell technology will soon emerge as an economically viable solution. The experts agree that the future belongs to the fuel cell. Indeed, it is quite possible that Jules Verne’s 1875 prediction – “water is the coal of the future” – will prove entirely accurate.

THE CHANCELLOR AT ELRINGKLINGER

The German Chancellor Dr. Angela Merkel has also shown interest in the performance of the latest fuel cell applications. At the recent International Motor Show (IAA) in Frankfurt, one of the automotive industry’s most important annual events, she stopped off at ElringKlinger’s booth to find out more about the latest developments relating to PEM fuel cell stacks. The stack is integrated as a fuel cell / battery hybrid system or range extender and is already in series production with a reduced number of cells.



Dr. Stefan Wolf, CEO of ElringKlinger AG, shows the German Chancellor a 300-cell PEM fuel cell stack constructed of metallic bipolar plates; it generates an electrical output of 63 kW_eL.

Global presence

49 sites

GERMANY

26%

SHARE OF SALES

3,877
EMPLOYEES

15
SITES

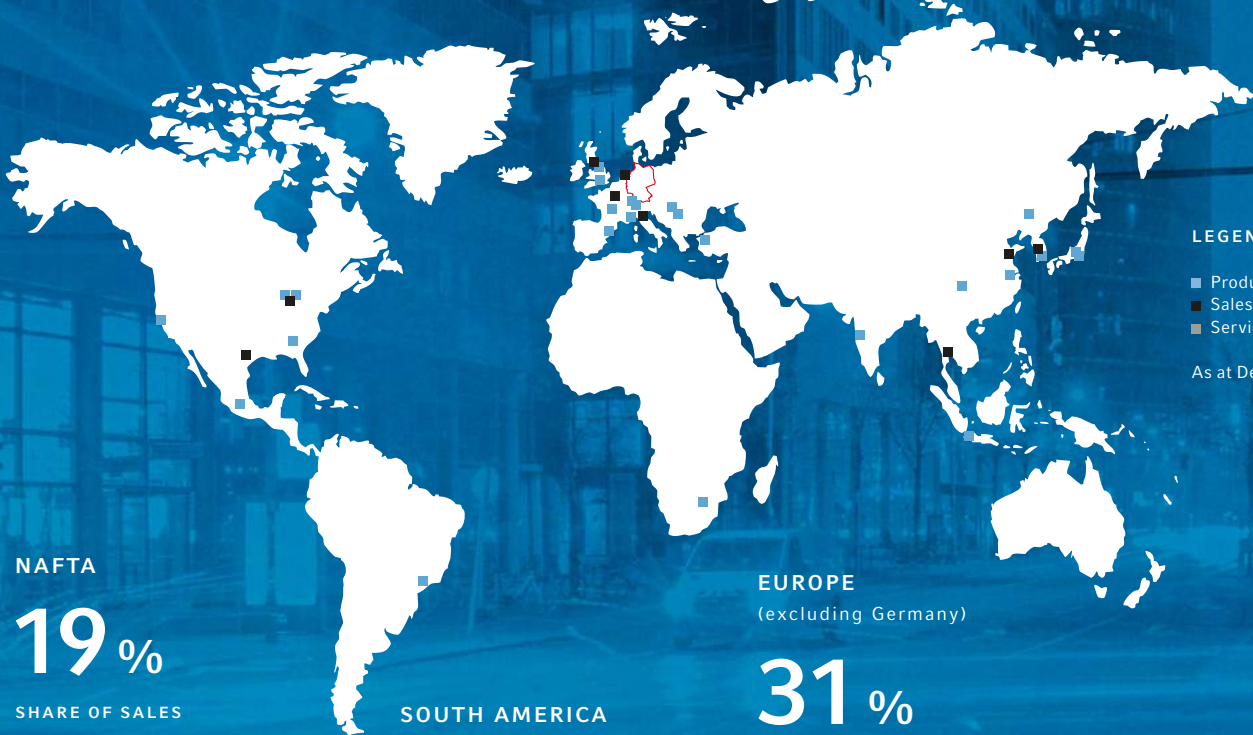
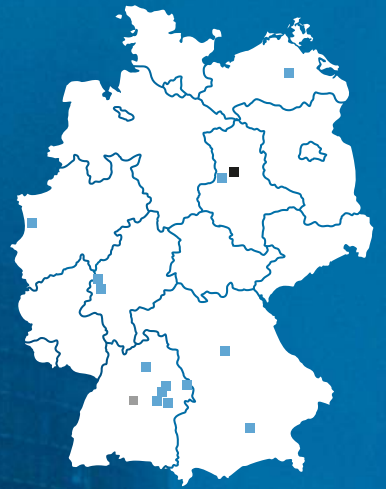

LEGEND

- Production
- Sales
- Services

As at December 31, 2017

NAFTA

19%

SHARE OF SALES

1,638
EMPLOYEES

7
SITES

SOUTH AMERICA
AND REST OF THE
WORLD

5%

SHARE OF SALES

394
EMPLOYEES

2
SITES

EUROPE

(excluding Germany)

31%

SHARE OF SALES

2,211
EMPLOYEES

14
SITES

ASIA-PACIFIC

19%

SHARE OF SALES

1,491
EMPLOYEES

11
SITES

Imprint

pulse

The ElringKlinger AG Magazine | Issue 2018

Published by

ElringKlinger AG
Max-Eyth-Straße 2
72581 Dettingen/Erms
Germany
Phone +49 7123 724 – 0
Fax +49 7123 724 – 9006
www.elringklinger.com

Editorial Team

Dr. Jens Winter (V.i.S.d.P.), Kathrin Graf,
Sabrina Haufler, Heiderose Mall,
Christoph Staib, Johannes Winterhagen

Concept & Design

3st kommunikation, Mainz

Picture Credits

Drew Bird, Gaby Höss, Mick Ryan,
Matthias Schmiedel, ElringKlinger AG, hofer AG,
Fraunhofer ISE, Shutterstock, ZSW

Illustration

Aleksandar Savić

Contact (Editorial Team)

E-mail investor-relations@elringklinger.com

Publication Details

“pulse” is published once a year together
with ElringKlinger’s annual report.

The magazine’s content is protected by copyright. Reprints
or the use of content – including excerpts – are prohibited
without the prior written consent of the editorial team.

For the purpose of readability, we have not used both forms
of grammatical gender (masculine and feminine) simultane-
ously when referring to specific terms. General designations
referring to people relate to all people irrespective of gender.

ElringKlinger AG shall assume no liability for figures and
statistics from third-party publications.



ElringKlinger AG
Max-Eyth-Straße 2
72581 Dettingen/Erms
(Germany)